

Technical data sheet

Product features



Freezing counter GN 1/1, 2 door, without splash back, stainless steel 230 V

Model	SAP Code	00021219
--------------	-----------------	----------



- Material: Stainless steel
- GN / EN size in device: GN 1/1
- Number of GN / EN: 2
- Number of doors: 2
- Control type: Digital
- Minimum device temperature [°C]: -18
- Maximum device temperature [°C]: -24
- Max ambient temperature [°C]: 43
- Insulation thickness [mm]: 70
- Unit: Right

SAP Code	00021219	Number of doors	2
Net Width [mm]	1380	Number of GN / EN	2
Net Depth [mm]	700	GN / EN size in device	GN 1/1
Net Height [mm]	900	Minimum device temperature [°C]	-18
Net Weight [kg]	110.00	Maximum device temperature [°C]	-24
Power electric [kW]	0.400	Refrigerant	R290
Loading	230 V / 1N - 50 Hz	Climate class	5
Energy class	G		

Technical data sheet

Technical drawing



Freezing counter GN 1/1, 2 door, without splash back, stainless steel 230 V

Model

SAP Code

00021219

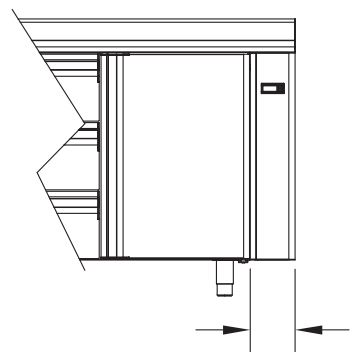
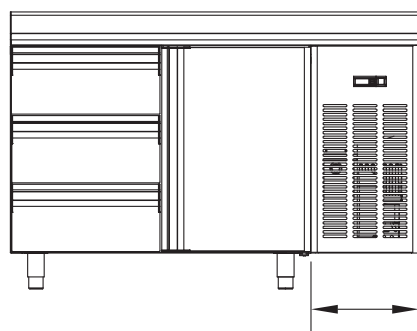
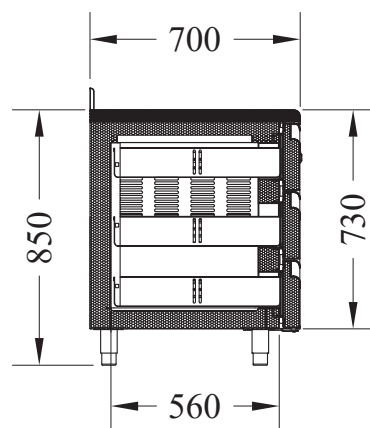
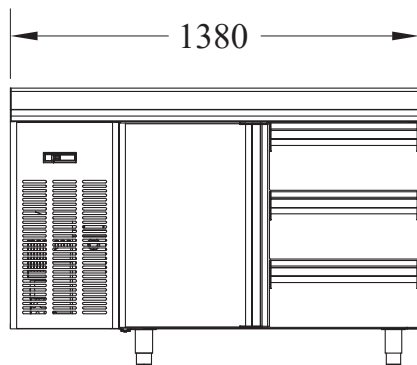
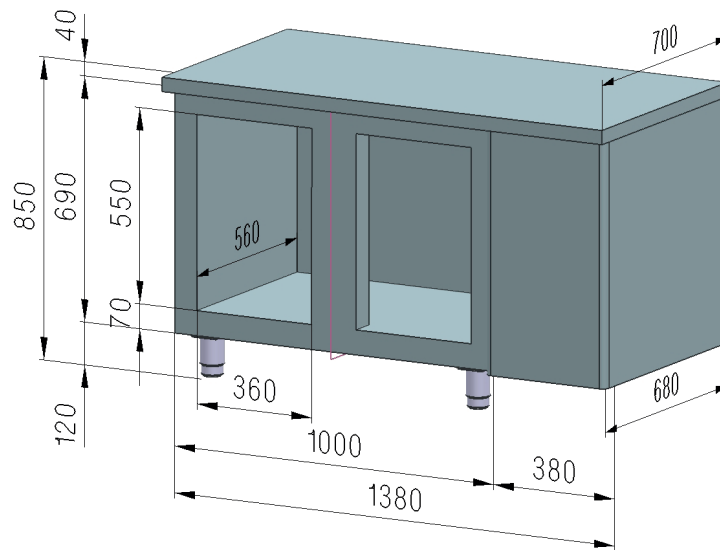

Technical data sheet

Product benefits



Freezing counter GN 1/1, 2 door, without splash back, stainless steel 230 V

Model

SAP Code

00021219

1

Climate class tropico

works up to 43 °C

- guaranteed operation even in a warm kitchen environment

2

Insulation 60mm

minimal losses

- low energy consumption
- less environmental burden

Technical data sheet

Technical parameters



Freezing counter GN 1/1, 2 door, without splash back, stainless steel 230 V

Model

SAP Code

00021219

1. SAP Code:

00021219

2. Net Width [mm]:

1380

3. Net Depth [mm]:

700

4. Net Height [mm]:

900

5. Net Weight [kg]:

110.00

6. Gross Width [mm]:

1450

7. Gross depth [mm]:

750

8. Gross Height [mm]:

950

9. Gross Weight [kg]:

140.00

10. Device type:

Electric unit

11. Power electric [kW]:

0.400

12. Loading:

230 V / 1N - 50 Hz

13. Energy class:

G

14. Refrigerant:

R290

15. Material:

Stainless steel

16. Max ambient temperature [°C]:

43

17. Device properties 2:

Freezing

18. GN / EN size in device:

GN 1/1

19. Number of GN / EN:

2

20. Adjustable feet:

Yes

21. Pizza design:

No

22. Insulation thickness [mm]:

70

23. Number of doors:

2

24. Unit:

Right

25. Control type:

Digital

26. Minimum device temperature [°C]:

-18

27. Maximum device temperature [°C]:

-24

28. Gross Volume [m3]:

1.033

Technical data sheet

Technical parameters



Freezing counter GN 1/1, 2 door, without splash back, stainless steel 230 V

Model	SAP Code	00021219
--------------	-----------------	----------

29. Net Volume [m3]:

0.869

30. Climate class:

5